



ENGINE

Model	Yanmar 3TNV88F-ESHYB
Emissions Certification	Tier 4 Final
Fuel	Diesel
Cylinders	3
Displacement	100.2 in ³ (1 642 cc)
Fuel injection	Mechanical w/electronic governor
Gross horsepower – SAE J1995 @ 2200 RPM:	24.4 hp (18.2 kW)
Net horsepower – SAE J1349 @ 2200 RPM:	23.7 hp (17.7 kW)
Maximum Engine Torque @ 1200 RPM:	69.4 lb ft (94.1 Nm)
Cooling	Water-cooled

DRIVETRAIN

Travel speeds:	
1st	1.6 mph (2.5 kph)
2nd	2.6 mph (4.2 kph)
Maximum traction force	6,835 lb (3 100 kg)
Gradeability	30° (58%)
Ground pressure:	
Canopy	N/A
Cab	4.83 psi (0.34 kgf/cm ²)

ELECTRICAL

Voltage	12 Volts
Alternator rating	55 amp
Battery	1 x 12 V x 70 Ah 750 CCA

OPERATOR ENVIRONMENT

ROPS/FOPS four post canopy or enclosed cab; ISO 6396:2008 sound pressure level LpA=75dB (A); Pilot operated hand controls and foot pedals; Adjustable seat w/seat belt; Arm rests; 12V socket.

Display includes:

Engine oil pressure warning lamp; Battery charging warning lamp; Engine preheat pilot lamp; Engine coolant temp warning lamp; Air cleaner warning lamp; Overload warning lamp; Travel speed pilot lamp; Fuel low level warning lamp; Air cleaner warning lamp; Hyd. quick coupler lock lamp; Engine coolant temp gauge; Fuel gauge and Hour meter.

OPERATING WEIGHT

Canopy operating weight:	
Short arm	7,990 lb (3 625 kg)
Long arm w/additional counterweight	8,350 lb (3 790 kg)
Cab operating weight:	
Short arm	8,300 lb (3 765 kg)
Long arm w/additional counterweight	8,660 lb (3 930 kg)

NOTE: w/rubber tracks/no quick coupler/bucket/fluids/full of fuel/165 lb operator.

HYDRAULICS

Main pumps:	Variable displacement tandem axial piston pump
Max rated flow x 2:	9.9 gpm (37.4 L/min)

Auxiliary flow @ 2,973 psi (205 bar):	
Primary	16.0 gpm (60.5 L/min)
Secondary	16.0 gpm (60.5 L/min)

System relief pressure:	
Standard	3,270 psi (230 bar)
Overload relief valve	3,560 psi (250 bar)

Pilot control hydraulic system:	
Pump	Gear Pump
Maximum capacity	2.6 gpm (9.9 L/min)

Control valves:

Pilot control for left/right track travel, boom, arm, bucket and swing
Manual control for breaker and backfill blade

Swing motor:	Fixed displacement axial piston motor Automatic spring applied hydraulic released brake
--------------	--

Travel motor:	Variable displacement axial piston 2-stage planetary Automatic spring applied hydraulic released brake
---------------	---

SERVICE CAPACITIES

Fuel tank	10.5 gal (40 L)
Hydraulic tank:	
Refill capacity	9.8 gal (37 L)
Total system	15.9 gal (60 L)
Engine oil w/filter change	1.8 gal (6.7 L)
Radiator	1.5 gal (5.5 L)

OTHER SPECIFICATIONS

Swing speed	0 – 9.5 RPM
Undercarriage:	
Track rollers	1 upper/4 lower each
Boom:	
Swing	75° left/50° right
Length	8 ft 2 in (2.5 m)
Arm:	
Standard length	4 ft 3 in (1.3 m)
Long arm length	5 ft 3 in (1.6 m)

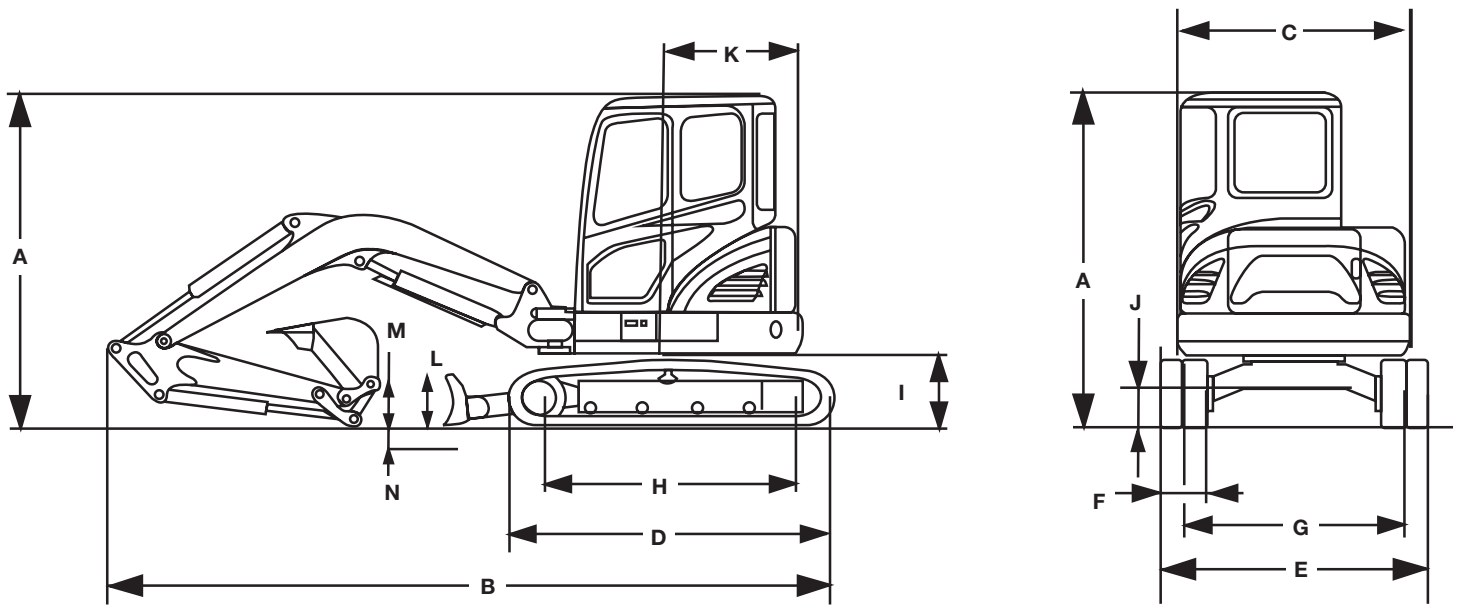

Line drawings are for illustrative purpose only and may not be exact representation of unit.

DIMENSIONS

	4 ft 3 in (1.3 m) Arm
A. Overall height	8 ft 2 in (2 500 mm)
B. Overall transport length	15 ft 9 in (4 790 mm)
C. Width of upper structure	5 ft 0 in (1 530 mm)
D. Track overall length	7 ft 0 in (2 130 mm)
E. Track overall width	5 ft 9 in (1 740 mm)
F. Track shoe width	12 in (300 mm)
G. Track gauge	4 ft 9 in (1 440 mm)
H. Center to center - idler to sprocket	5 ft 7 in (1 700 mm)
I. Upper structure ground clearance	1 ft 9 in (540 mm)
J. Minimum ground clearance	11 in (290 mm)
K. Tail swing radius:	
Standard counterweight	2 ft 10 in (870 mm)
Additional counterweight	3 ft 3 in (985 mm)
Boom swing	75° left/50° right
Tail swing overhang:	
Standard counterweight	0 in (0 mm)
Additional counterweight	5 in (115 mm)

BLADE SPECS

L. Backfill blade height	1 ft 3 in (370 mm)
M. Backfill blade rise above ground	1 ft 3 in (375 mm)
N. Backfill blade dig depth	1 ft 3 in (390 mm)
Backfill blade width	5 ft 9 in (1 740 mm)

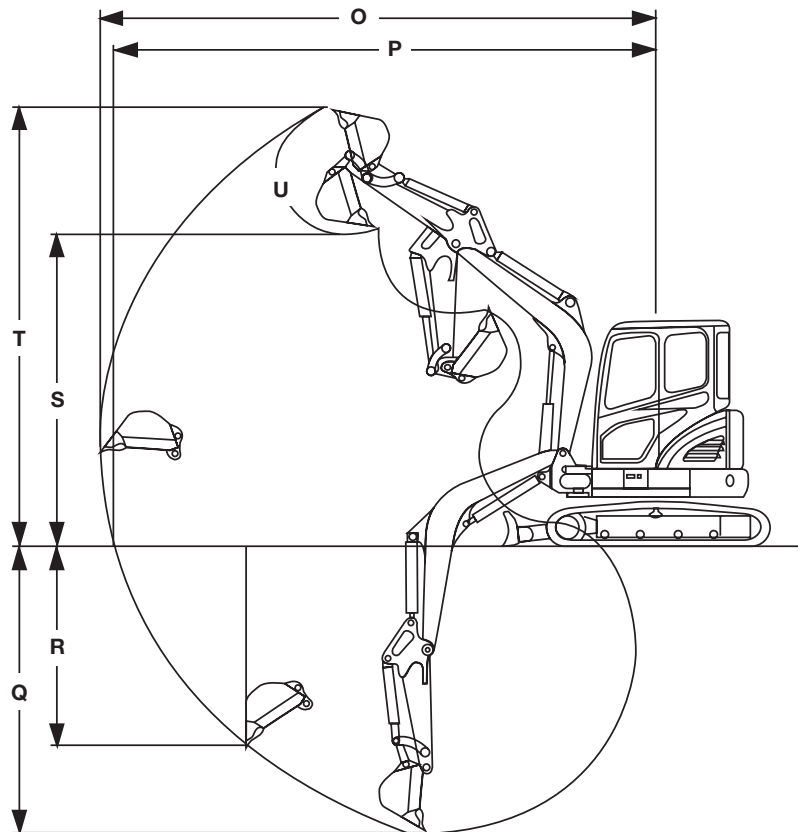

PERFORMANCE SPECS

	4 ft 3 in (1.3 m) Arm	5 ft 3 in (1.6 m) Arm
O. Maximum dig radius	17 ft 5 in (5 315 mm)	18 ft 5 in (5 605 mm)
P. Dig radius at groundline	17 ft 1 in (5 200 mm)	18 ft 0 in (5 495 mm)
Q. Maximum dig depth	10 ft 3 in (3 135 mm)	11 ft 3 in (3 440 mm)
R. Vertical straight wall dig depth	7 ft 2 in (2 190 mm)	8 ft 5 in (2 565 mm)
S. Dump height	11 ft 3 in (3 425 mm)	11 ft 10 in (3 615 mm)
T. Overall reach height	15 ft 9 in (4 810 mm)	16 ft 7 in (5 010 mm)
U. Bucket rotation	180°	180°
Arm digging force - ISO	4,390 lbf (1 990 kgf/19.5 kN)	3,800 lbf (1 720 kgf/16.9 kN)
Bucket digging force - ISO	6,900 lbf (3 130 kgf/30.7 kN)	6,900 lbf (3 130 kgf/30.7 kN)

LIFT CAPACITIES

8 ft 2 in (2.5 m) Boom, 4 ft 3 in (1.3 m) Arm, Dozer Blade Down Canopy unit equipped with 0.11 m³ (SAE heaped) bucket, 12 in (300 mm) rubber track and 900 lb (410 kg) counterweight.

Load / Lift Point Height	LOAD RADIUS								MAXIMUM REACH			
	3 ft (1.0 m)		7 ft (2.0 m)		10 ft (3.0 m)		13 ft (4.0 m)		REACH	CAPACITY		
	END	SIDE	END	SIDE	END	SIDE	END	SIDE		@	END	SIDE
+10 ft (3.0 m)										12 ft 11 in (3.94 m)	1,170 lb* (530 kg)*	1,070 lb (490 kg)
+7 ft (2.0 m)					1,380 lb* (630 kg)*	1,380 lb* (630 kg)*	1,210 lb* (550 kg)*	1,020 lb (460 kg)	14 ft 7 in (4.45 m)	1,190 lb* (540 kg)*	830 lb (380 kg)	
+3 ft (1.0 m)					1,990 lb* (900 kg)*	1,540 lb (700 kg)	1,400 lb* (640 kg)*	970 lb (440 kg)	15 ft 3 in (4.64 m)	1,240 lb* (560 kg)*	750 lb (340 kg)	
Groundline			2,990 lb* (1 320 kg)*	2,500 lb (1 130 kg)	2,410 lb* (1 090 kg)*	1,440 lb (650 kg)	1,570 lb* (710 kg)*	920 lb (420 kg)	14 ft 11 in (4.55 m)	1,320 lb* (600 kg)*	750 lb (340 kg)	
-3 ft (-1.0 m)	3,840 lb* (1 740 kg)*	3,840 lb* (1 740 kg)*	4,330 lb* (1 960 kg)*	2,800 lb (1 270 kg)	2,390 lb* (1 090 kg)*	1,410 lb (640 kg)	1,520 lb* (690 kg)*	910 lb (410 kg)	13 ft 8 in (4.17 m)	1,400 lb* (640 kg)*	860 lb (390 kg)	
-7 ft (-2.0 m)	5,680 lb* (2 580 kg)*	5,680 lb* (2 580 kg)*	3,190 lb* (1 450 kg)*	2,980 lb (1 310 kg)	1,840 lb* (830 kg)*	1,460 lb (660 kg)			11 ft 0 in (3.36 m)	1,470 lb* (670 kg)*	1,230 lb (560 kg)	

NOTE: Lifting capacity are based on ISO 10567.

Lifting capacity does not exceed 75% of tipping load with the machine on firm, level ground or 87% of full hydraulic capacity.

The lift point is a hook located on the back of the bucket.

*Indicates load limited by hydraulic capacity.

8 ft 2 in (2.5 m) Boom, 5 ft 3 in (1.6 m) Arm, Dozer Blade Down Canopy unit equipped with 0.11 m³ (SAE heaped) bucket, 12 in (300 mm) rubber track and 1,235 lb (560 kg) counterweight.

Load / Lift Point Height	LOAD RADIUS								MAXIMUM REACH		
	3 ft (1.0 m)		7 ft (2.0 m)		10 ft (3.0 m)		13 ft (4.0 m)		REACH	CAPACITY	
	END	SIDE	END	SIDE	END	SIDE	END	SIDE		@	END
+10 ft (3.0 m)							970 lb* (440 kg)*	970 lb* (440 kg)*	14 ft 2 in (4.32 m)	970 lb* (440 kg)*	970 lb* (440 kg)*
+7 ft (2.0 m)							1,060 lb* (480 kg)*	1,060 lb* (480 kg)*	15 ft 8 in (4.78 m)	940 lb* (420 kg)*	840 lb (380 kg)
+3 ft (1.0 m)			3,710 lb* (1 680 kg)*	3,390 lb (1 540 kg)	1,770 lb* (800 kg)*	1,760 lb (800 kg)	1,290 lb* (590 kg)*	1,110 lb (500 kg)	16 ft 3 in (4.95 m)	990 lb* (450 kg)*	760 lb (350 kg)
Groundline			3,060 lb* (1 390 kg)*	3,060 lb* (1 390 kg)*	2,300 lb* (1 040 kg)*	1,630 lb (740 kg)	1,510 lb* (680 kg)*	1,050 lb (470 kg)	16 ft 0 in (4.87 m)	1,140 lb* (520 kg)*	760 lb (350 kg)
-3 ft (-1.0 m)	3,040 lb* (1 380 kg)*	3,040 lb* (1 380 kg)*	4,610 lb* (2 090 kg)*	3,090 lb (1 400 kg)	2,420 lb* (1 100 kg)*	1,580 lb (720 kg)	1,560 lb* (710 kg)*	1,020 lb (460 kg)	14 ft 10 in (4.52 m)	1,250 lb* (570 kg)*	850 lb (380 kg)
-7 ft (-2.0 m)	4,610 lb* (2 090 kg)*	4,610 lb* (2 090 kg)*	3,720 lb* (1 690 kg)*	3,160 lb (1 430 kg)	2,080 lb* (940 kg)*	1,600 lb (730 kg)			12 ft 6 in (3.81 m)	1,340 lb* (610 kg)*	1,120 lb (510 kg)

NOTE: Lifting capacity are based on ISO 10567.

Lifting capacity does not exceed 75% of tipping load with the machine on firm, level ground or 87% of full hydraulic capacity.

The lift point is a hook located on the back of the bucket.

*Indicates load limited by hydraulic capacity.

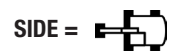
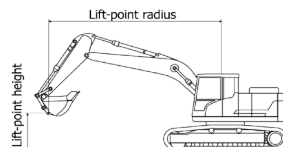

STANDARD EQUIPMENT

ENGINE

Yanmar 3TNV88F-ESHYB
Glow plug starting aid
Dry type air cleaner with restriction indicator

ELECTRICAL

12-volt electrical starting system
Heavy-duty battery
Battery Master Switch
Key Start
Anti-Theft-Engine starting passwords
Front working light
Auto-idle feature with on/off switch
Horn
Pre-wired – Telematics ready

HYDRAULICS

Auxiliary hydraulics – single/bi-directional –
and plumbing to arm
Large hydraulic oil cooler
Control pattern selector valve
Cylinder rod protection covers – Dozer, Boom

TRACK DRIVE

Rubber belt tracks
Automatic 2-speed travel
Fully hydrostatic drive system
Sealed and lubricated track rollers
Track tension adjustment – grease type

UPPER STRUCTURE

Zero tail swing
Standard arm: 4 ft 3 in (1.3 m)
Bucket linkage with lifting hook
Thumb bracket

OPERATOR ENVIRONMENT

See page 1

OTHER

Swing boom – 75° left/50° right
Hydraulic backfill blade

WARRANTY

Base warranty coverage: 2-Year/3,000-Hour
Full Machine Limited Warranty

OPTIONAL EQUIPMENT

OPERATOR ENVIRONMENT

Cab with Heat and air conditioning and radio
with USB and 2 speakers
Travel alarm

TRACK OPTIONS

Tracks:
Steel Tracks 12 in (300 mm)

OTHER

Additional counterweight adds 330 lb (150 kg)
Optional long arm: 5 ft 3 in (1.6 m)
Hydraulic quick coupler provision
Hydraulic coupler
Klacc coupler
Mechanical coupler
Hydraulic hammer
Beacon
2nd auxiliary circuit
Steel Tracks

CaseCE.com

©2017 CNH Industrial America LLC. All rights reserved. CASE is a trademark registered in the United States and many other countries, owned by or licensed to CNH Industrial N.V., its subsidiaries or affiliates. CNH Industrial Capital is a trademark in the United States and many other countries, owned by or licensed to CNH Industrial N.V., its subsidiaries or affiliates. Printed in U.S.A. Contains 10% post-consumer fiber.

IMPORTANT: CASE Construction Equipment Inc. reserves the right to change these specifications without notice and without incurring any obligation relating to such change. Availability of some models and equipment builds vary according to the country in which the equipment is used. The illustrations and text may include optional equipment and accessories and may not include all standard equipment. Your CASE dealer/distributor will be able to give you details of the products and their specifications available in your area.



CASE Construction Equipment is biodiesel-friendly. NOTE: All engines meet current EPA emissions regulations. All specifications are stated in accordance with SAE Standards or Recommended Practices, where applicable.



Always read the Operator's Manual before operating any equipment. Inspect equipment before using it, and be sure it is operating properly. Follow the product safety signs and use any safety features provided.

Form No. CCE201709CX37C
Replaces Form No. CCE201707CX37C

CX37C

4 of 4