

**ENGINE**

Make	Cummins Tier 3 Certified
Model	QSB 3.3 C99
Gross horsepower	99 hp (73.8 kW)

**ELECTRICAL**

Voltage	24 Volts
Batteries	2 x 61 amp
Alternator	45 amp

**STEERING**

Pump (gear type)	1
Cylinders	2
Angle (left & right)	36°
Oscillation angle	12°
Inside turning radius	10.2 ft (3.09 m)
Outside turning radius	15.3 ft (4.68 m)

**WEIGHT - SMOOTH DRUM**

Operating weight without cab	15,830 lbs (7180 kg)
Max. weight with cab	16,010 lbs (7260 kg)
Drum weight	8,844 lbs (4012 kg)
Static linear load	134 lb/in (23.9 kg/cm)
Tire ballast	2,646 lbs (1200 kg)

**WEIGHT - PADFOOT DRUM**

Operating weight without cab	26,500 lbs (12 020 kg)
Max weight with cab	26,990 lbs (12 242 kg)
Tire ballast	2,646 lbs (1200 kg)

**TRAVEL**

Hydraulic circuit type	Closed
Variable displacement axial piston type wheel drive pump	1
Hydraulic fixed displacement wheel drive motors	2
Drive motor interlock	Yes
Hydraulic variable displacement drum drive motor	1
F/R travel speed range	4
Working speeds	mph (km/h)
1st (max)	1.6 (2.5)
2nd (max)	2.2 (3.5)
3rd (max)	2.9 (4.7)
Max travel speed	6.8 (11.0)
Gradeability (without traction assist)	50%
Transversal stability (machine in straight line)	32° slope

**VIBRATION**

Hydraulic circuit type	Closed
Variable displacement axial piston type pump	1
Fixed displacement hydraulic motor	1
Vibration modes	2
Vibration	2 eccentric weights circular pattern / continuously adjustable
Frequency	
Low	1800 VPM (30 Hz)
High	2460 VPM (41 Hz)
Amplitude	
Low	.034 in (.86 mm)
High	.069 in (1.7 mm)
Centrifugal force	
Low	29,215 lbs (130 kN)
High	32,586 lbs (145 kN)

**TIRES**

Size	14.9 x 24 8PR
Smooth drum	Diamond or traction tread
Padfoot drum	Traction tread
Tire ballast	Traction tread only

**CAPACITIES**

Fuel tank	72.7 gal (275 L)
Engine oil	12 qt (11 L)
Engine coolant	20 qt (19 L)
Hydraulic reservoir	77 qt (73 L)
Transmission	2.6 qt (2.5 L)
Drive axle	2.6 qt (2.5 L)
Vibration system	7.1 qt (6.7 L)

**OPERATOR STATION**

Isolated from chassis by flexible shock absorbers, handrail, dual rearview mirrors, front lighting, instrument panel anti-vandal guard. Vinyl suspension seat with armrests and 2 inch (51 mm) retractable seat belt. Exceptional front/rear visibility.

**STANDARD EQUIPMENT**

- ROPS & FOPS protection
- Hydrostatic drive for both drum and wheels
- Dual amplitude vibration
- Interwheel differential lock
- Articulated chassis
- Front and rear tow points
- 4-point lift and tie-down provision
- Fan guard
- Backup alarm
- Halogen work lights, 2F/2R
- Auto-vibration control
- Master disconnect switch
- Spring applied, hydraulic release parking brake
- 3 working speeds / 1 transport speed
- Single lever speed / direction control
- Steering wheel spinner knob
- Lockable tool box
- Cup holder
- Horn
- Emergency stop button
- Spin-on fuel, engine oil and hydraulic filters
- LCD monitor

## OPTIONAL EQUIPMENT

### Traction Assist Systems

- ASC-anti-slip control (smooth drum option only)
- HD-heavy duty (includes ASC; smooth drum or padfoot drum)
- HT-high traction (includes ASC; padfoot drum with leveling blade only)

Padfoot shell kit with scrapers

Pressurized cab with heat and ventilation

- Air conditioning
- Radio ready (antenna and 2 speakers / no radio)

Engine filter pre-cleaner

Electric engine hood tilt

3 in (76.2 mm) retractable seat belt

Compaction meter system (Voelkel)

Compaction meter printer

Side slope rollover warning system

Rotating beacon

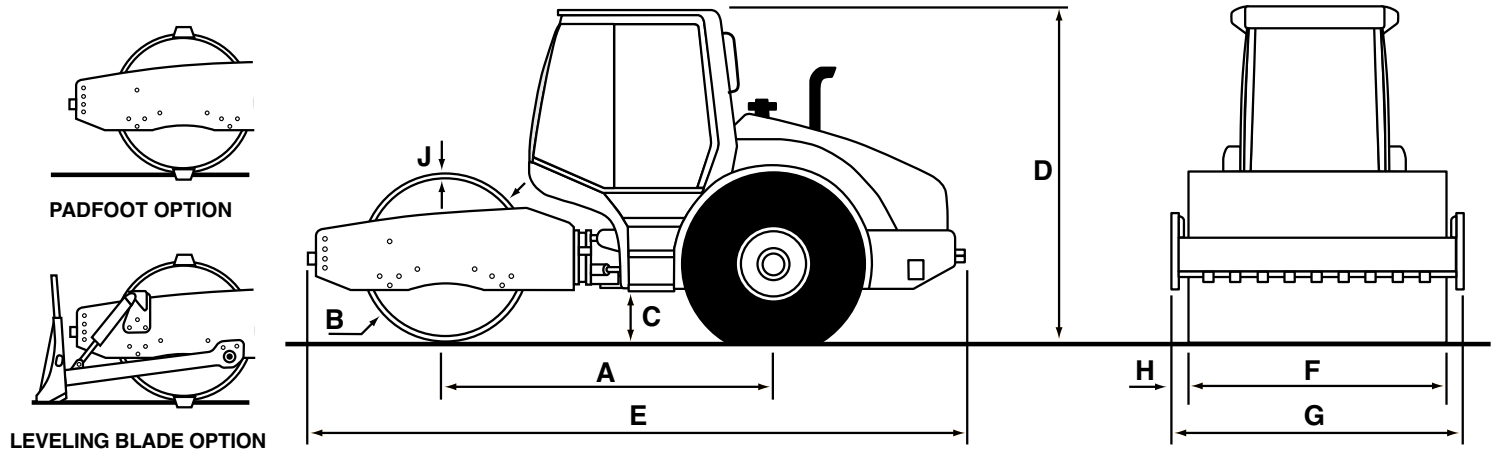

## DIMENSIONS

<b>A.</b>	Wheel base	100.8 in (2.6 m)
<b>B.</b>	Drum diameter	
	Smooth drum	51 in (1.3 m)
	Padfoot drum	55 in (1.4 m)
<b>C.</b>	Ground clearance	15.2 in (0.39 m)
<b>D.</b>	Overall height	113 in (2.87 m)
<b>E.</b>	Overall length	205 in (5.2 m)
<b>F.</b>	Drum width	66 in (1.68 m)
<b>G.</b>	Overall width	67.7 in (1.7m)
<b>H.</b>	Frame extensions	1.4 in (0.035 m)
<b>J.</b>	Drum thickness	1.0 in (0.025 m)



NOTE: All specifications are stated in accordance with SAE Standards or Recommended Practices, where applicable.

NOTE: All engines meet current EPA emissions requirements.

IMPORTANT: Case Construction Equipment Inc. reserves the right to change these specifications without notice and without incurring any obligation relating to such change. Case Construction Equipment Inc. does not warrant the safety or reliability of attachments from other manufacturers.

Case is a registered trademark of CNH America LLC. Any trademarks referred to herein, in association with goods and/or services of companies other than CNH America LLC, are the property of those respective companies.



[www.casece.com](http://www.casece.com)

